



LED WATTAGE CHART

	16L
400 milliamps	21w
530 milliamps	26w
700 milliamps	35w

The Radian Bollard is a fusion of contemporary design and state of the art lighting technology. The performance of this bollard produces a smooth uniform light pattern at a broad angle at extremely efficient low wattages.

The Radian is available in 3000, 4000 or 5000 Kelvin temperatures to blend with any residential, retail, or pathway environment. The lens is standard clear with Paracline Optic.

BUY AMERICAN

To ensure the latest BAA/TAA/BABA Standards are being met, please select BAA, TAA, or BABA in the options section. Please contact the factory before placing an order for any NLS products requesting BAA (Buy American Act), TAA (Trade American Act), or BABA (Build America, Buy America).



Project Name:

Type:

RADIAN BOLLARD ORDERING GUIDE

Cat#	Height	Shaft Dim.	Light Dist.	# of LEDs	Miliamps
Radian (RDN)	20" (2)	6" Round (6R)	Type 5 (T5)	16 (16L)	400 (40)
	30" (3)				530 (53)
	40" (4)				700 (7)

Kelvin	Volts	Mounting	Color	Options
Amber 585-600nM (AMBER) 4, 6, 7	120-277 (UNV)	Anchor Base (AB)	Bronze Textured (BRZ)	Button Photocell (PC) 2
Amber LED Phosphor Converted (AMBER/PC) 6, 7	347-480 (HV)		White Textured (WHT)	Vandal Resistant Base (VRB)
2700K, 70 CRI (27K7)			Smooth White Gloss (SWT)	Marine Grade Finish (MGF)
2700K, 80 CRI (27K8) 1			Silver Metallic (SVR)	Emergency Battery Back-Up 4 W (EM4) 2
3000K, 70 CRI (30K7)			Black Textured (BLK)	Emergency Battery Back-Up 8 W (EM8) 2
3000K, 80 CRI (30K8) 1			Smooth Black Gloss (SBK)	House Side Shield (HSS)
3500K, 80 CRI (35K8) 1			Graphite Textured (GPH)	Buy American Act (BAA) 5
4000K, 70 CRI (40K7)			Grey Textured (GRY)	Trade Agreement Act (TAA) 5
4000K, 80 CRI (40K8) 1			Green Textured (GRN)	Build America Buy American (BABA) 5
5000K, 70 CRI (50K7)			Hunter Green Textured (HGN)	Custom Controls Integration (CCI) 3
5000K, 80 CRI (50K8) 1			Custom (CS)	Integral GFCI Outlet (GFCI) 8, 9
				USB Charging Outlet (USB) 8, 10

NOTES:

1. Consult Factory for Lead Time. Consult Factory for 90 CRI Requests
2. Universal Voltage 120-277
3. Please contact Factory for Custom Control Integration requests (nLight, NX, WaveLinx, Crestron, DMX/RDM, Synapse, Casambi, Dali II, Avi-On, or other control systems)
4. Turtle Safe
5. Consult factory for all BAA/TAA/BABA requests
6. Consult Factory for Lead Time
7. Not Available above 530mA
8. 120V Only
9. GFCI installed 12" from base, street side. Contact Factory for custom height
10. USB - Specify location.



701 Kingshill Place, Carson, CA 90746
Call Us Today (310) 341-2037

nlsighting.com

PRODUCT SPECIFICATIONS

ELECTRICAL

- 120-277 Volts (UNV) or 347-480 Volts (HV)
- 0-10V dimming driver
- Driver power factor at maximum load is $\geq .95$, THD maximum load is 15%
- LED Drivers Ambient Temp. Min is -40°C and Ambient Temp. Max ranges from 50°C to 55°C and, in some cases, even higher. Consult the factory for revalidation by providing the fixture catalog string before quoting and specifying it.
- All internal wiring UL certified for 600 VAC and 105°C
- CRI 70, 80, or 90
- Color temperatures: Amber, 2700K, 3000K, 3500K, 4000K, or 5000K
- Surge Protection: 20kA supplied as standard.

CONSTRUCTION

- Extruded Aluminum. Cast Aluminum. Spun Aluminum

OPTIONS

- MARINE GRADE FINISH (MGF) - A multi-step process creating protective finishing coat against harsh environments. Chemically washed in a 5 stage cleaning system. Pre-baked, Powder coated 3-5 mils of Zinc Rich Super Durable Polyester Primer. Oven Baked. Finished Powder Coating of Super Durable Polyester Powder Coat 3-5 mil thickness.
- VANDAL RESISTANT BASE (VRB)
- EMERGENCY BATTERY BACK-UP (EM)
- House Side Shield (HSS)
- Integral GFCI Outlet (GFCI)
- USB Charging Outlet (USB)

CONTROL OPTIONS

- PHOTOCCELL (PC) - Button Type
- Controls Agnostic: Please contact factory for your preferred controls option. (nLight, NX, WaveLinx, Crestron, DMX/RDM, Synapse, Casambi, DALI II, Avi-On, or other control systems)

FINISH

- 3-5 mils electrostatic powder coat.
- NLS Lighting standard high-quality finishes prevent corrosion and protects against extreme environmental conditions
- 10 Standard Finishes, Custom Finish and Marine Grade Finish Available

WARRANTY

Five-year limited warranty for drivers and LEDs.

BUY AMERICAN OPTION

While all of the NLS Lighting products listed in this document qualify for the Buy America(n) Act of 1933, we reserve the right to change our listings without notice.

The information provided above is for general informational purposes only. We encourage you to consult legal professionals for advice particular to your projects concerning BAA, TAA, BABA or Buy America.

Additional NLS Products that meet BAA, TAA standards can be found at the following link:

<https://nslighting.com/buy-american/>



The information and specifications on this document are subject to change without any notification. All values are design, nominal, or typical or prorated values when measured under internal and external laboratory conditions.



701 Kingshill Place, Carson, CA 90746
Call Us Today (310) 341-2037

nslighting.com

PRODUCT SPECIFICATIONS

DIMENSION	RDN
A	20" - 40"
B	6" OD

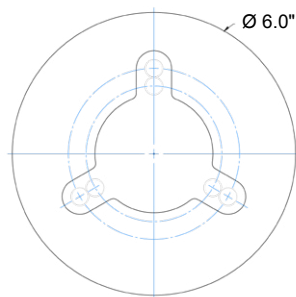
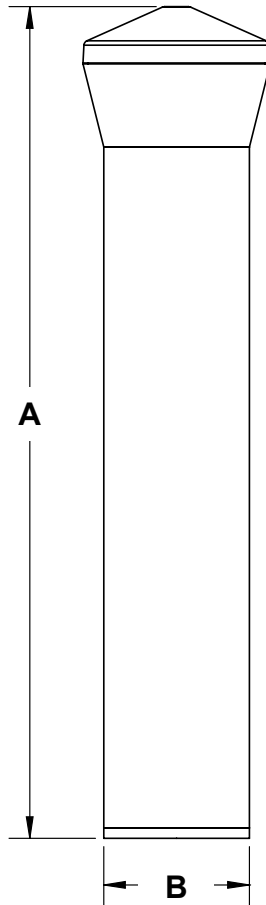
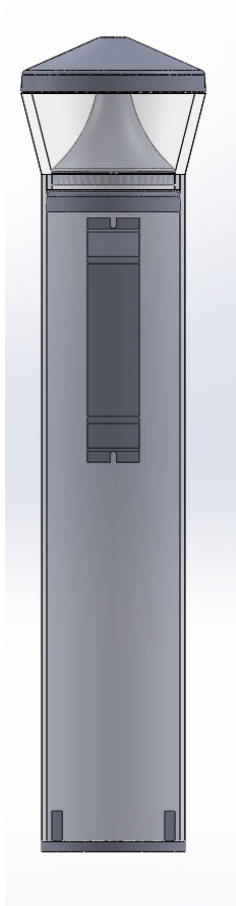

PRODUCT SPECIFICATIONS

LED KELVIN RANGE

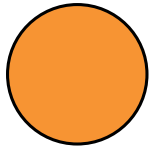

AMBER
585-600 nm

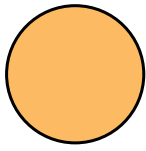

2700K 70 CRI

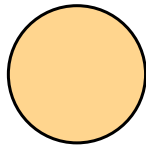

3000K 70 CRI

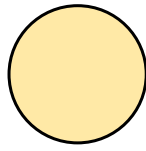

3500K 80 CRI

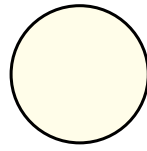

4000K 70 CRI

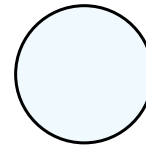

5000K 70 CRI

Color	Dominant or Peak Wavelength Range (nm)	
	Minimum	Maximum
Amber	585	600

LUMEN MAINTENANCE DATA							
Ambient Temperature	Drive Current	L90 Hours*	L70 Hours**	30,000 Hours*	50,000 Hours*	60,000 Hours*	100,000 Hours**
25°C	Up to 700mA	58,000	173,000	95.7%	91.6%	89.6%	82.1%
*Reported extrapolations per IESNA TM-21				**Projected extrapolations per IESNA TM-21			

RADIANT BOLLARD - LUMEN DATA CHART			
PART NUMBER	T5 LUMENS	T5 Lm/W	WATTS
RDN-16L-40-27K7	2036	97	21
RDN-16L-40-27K8	1907	91	21
RDN-16L-40-30K8	2044	97	21
RDN-16L-40-30K7	2202	105	21
RDN-16L-40-35K8	2044	97	21
RDN-16L-40-40K8	2202	105	21
RDN-16L-40-40K7	2379	113	21
RDN-16L-40-50K8	2202	105	21
RDN-16L-40-50K7	2379	113	21
RDN-16L-53-30K7	3,173	122	26
RDN-16L-53-40K7	3,331	128	26
RDN-16L-53-50K7	3,331	128	26
RDN-16L-7-30K7	3,966	113	35
RDN-16L-7-40K7	4,164	119	35
RDN-16L-7-50K7	4,164	119	35

PRODUCT SPECIFICATIONS

MARINE GRADE FINISH (MGF)

The **(MGF)** is a multi step process. Chemically washed in a 5 stage cleaning system. Pre-baked. Powder coated 3-5 mils of Zinc Rich Super Durable Polyester Primer. Oven Baked.

Finished Powder Coating of Super Durable Polyester Powder Coat 3-5 mil thickness.

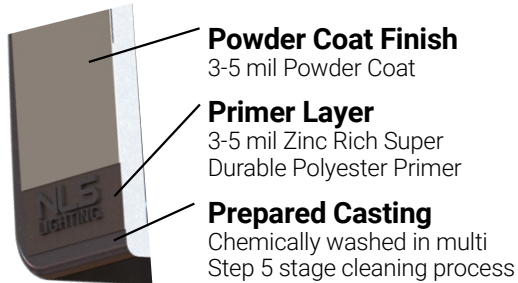

BUTTON TYPE PHOTOCELL (PC)

Photocell for dusk to dawn operation.
Consult Factory.

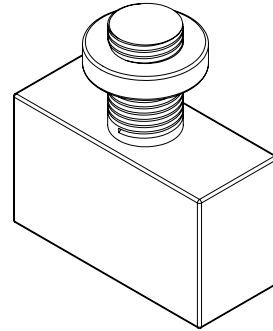

LEVELING NUT DIAGRAM

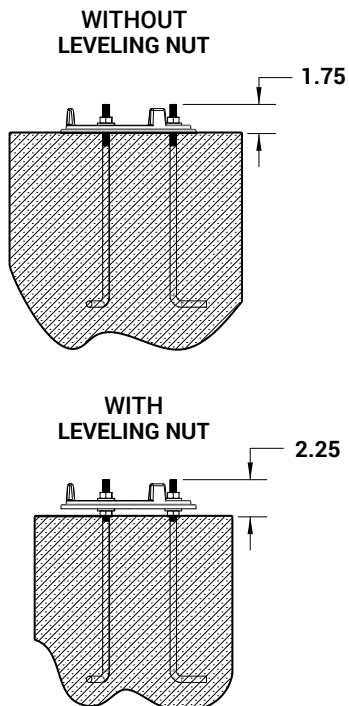

SHIELDING OPTIONS (HSS)

- SHIELDS (HSS)—House Side Shield (HSS) is designed for full property line cut-off.

HOUSE SIDE SHIELD

